

Feedforward and Ratio Control

In Chapter 8 it was emphasized that feedback control is an important technique that is widely used in the process industries. Its main advantages are as follows.

1. Corrective action occurs as soon as the controlled variable deviates from the set point, regardless of the source and type of disturbance.
2. Feedback control requires minimal knowledge about the process to be controlled; in particular, a mathematical model of the process is *not* required, although it can be very useful for control system design.
3. The ubiquitous PID controller is both versatile and robust. If process conditions change, retuning the controller usually produces satisfactory control.

However, feedback control also has certain inherent disadvantages:

1. No corrective action is taken until after a deviation in the controlled variable occurs. Thus, *perfect control*, where the controlled variable does not deviate from the set point during disturbance or set-point changes, is theoretically impossible.
2. Feedback control does not provide predictive control action to compensate for the effects of known or measurable disturbances.
3. It may not be satisfactory for processes with large time constants and/or long time delays. If large and frequent disturbances occur, the process may operate continuously in a transient state and never attain the desired steady state.
4. In some situations, the controlled variable cannot be measured on-line, and, consequently, feedback control is not feasible.

Introduction to Feedforward Control

The basic concept of feedforward control is to measure important disturbance variables and take corrective action before they upset the process. Feedforward control has several disadvantages:

1. The disturbance variables must be measured on-line. In many applications, this is not feasible.
2. To make effective use of feedforward control, at least a crude process model should be available. In particular, we need to know how the controlled variable responds to changes in both the disturbance and manipulated variables. The quality of feedforward control depends on the accuracy of the process model.
3. Ideal feedforward controllers that are theoretically capable of achieving perfect control may not be physically realizable. Fortunately, practical approximations of these ideal controllers often provide very effective control.

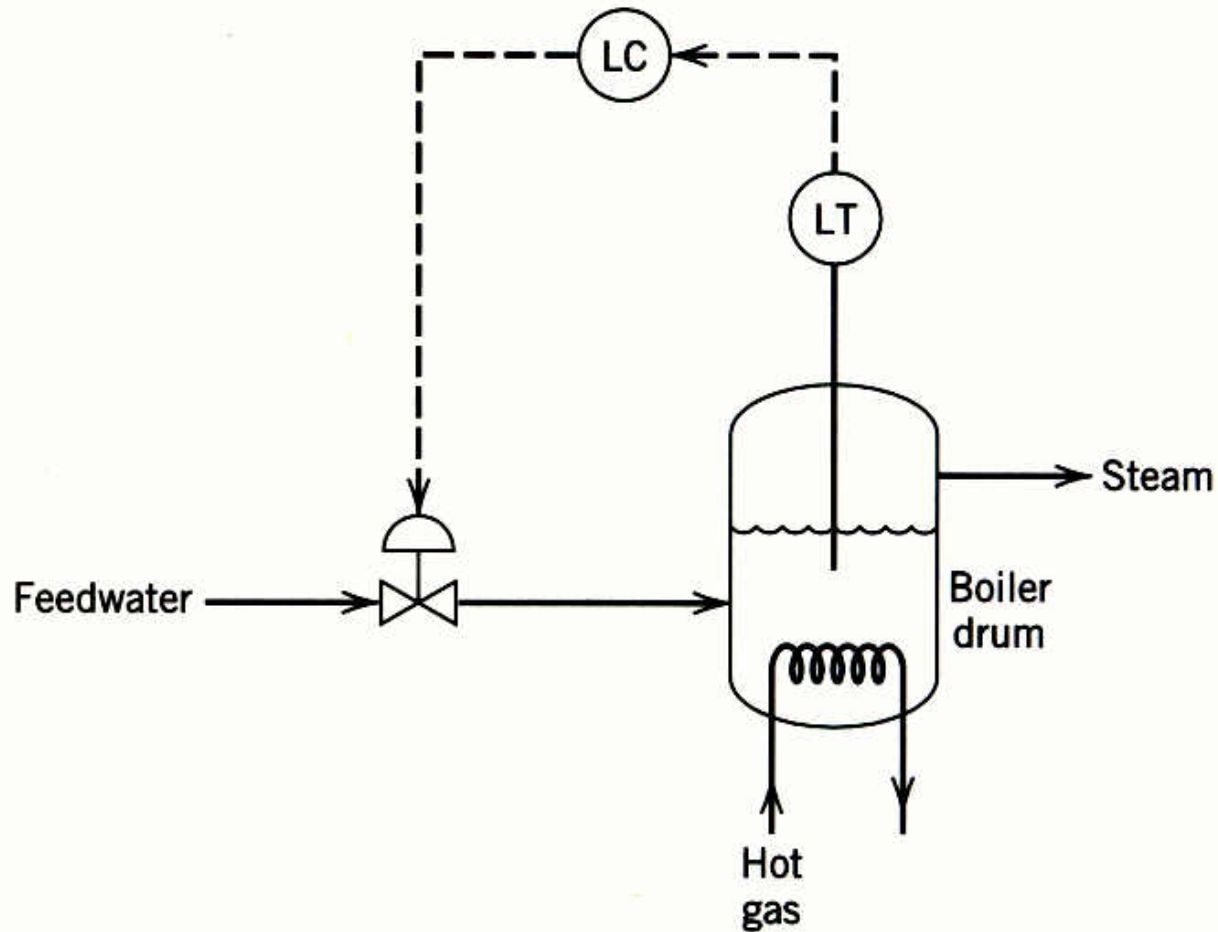

Figure 15.2 The feedback control of the liquid level in a boiler drum.

- A boiler drum with a conventional feedback control system is shown in Fig. 15.2. The level of the boiling liquid is measured and used to adjust the feedwater flow rate.
- This control system tends to be quite sensitive to rapid changes in the disturbance variable, steam flow rate, as a result of the small liquid capacity of the boiler drum.
- Rapid disturbance changes can occur as a result of steam demands made by downstream processing units.

The feedforward control scheme in Fig. 15.3 can provide better control of the liquid level. Here the steam flow rate is measured, and the feedforward controller adjusts the feedwater flow rate.

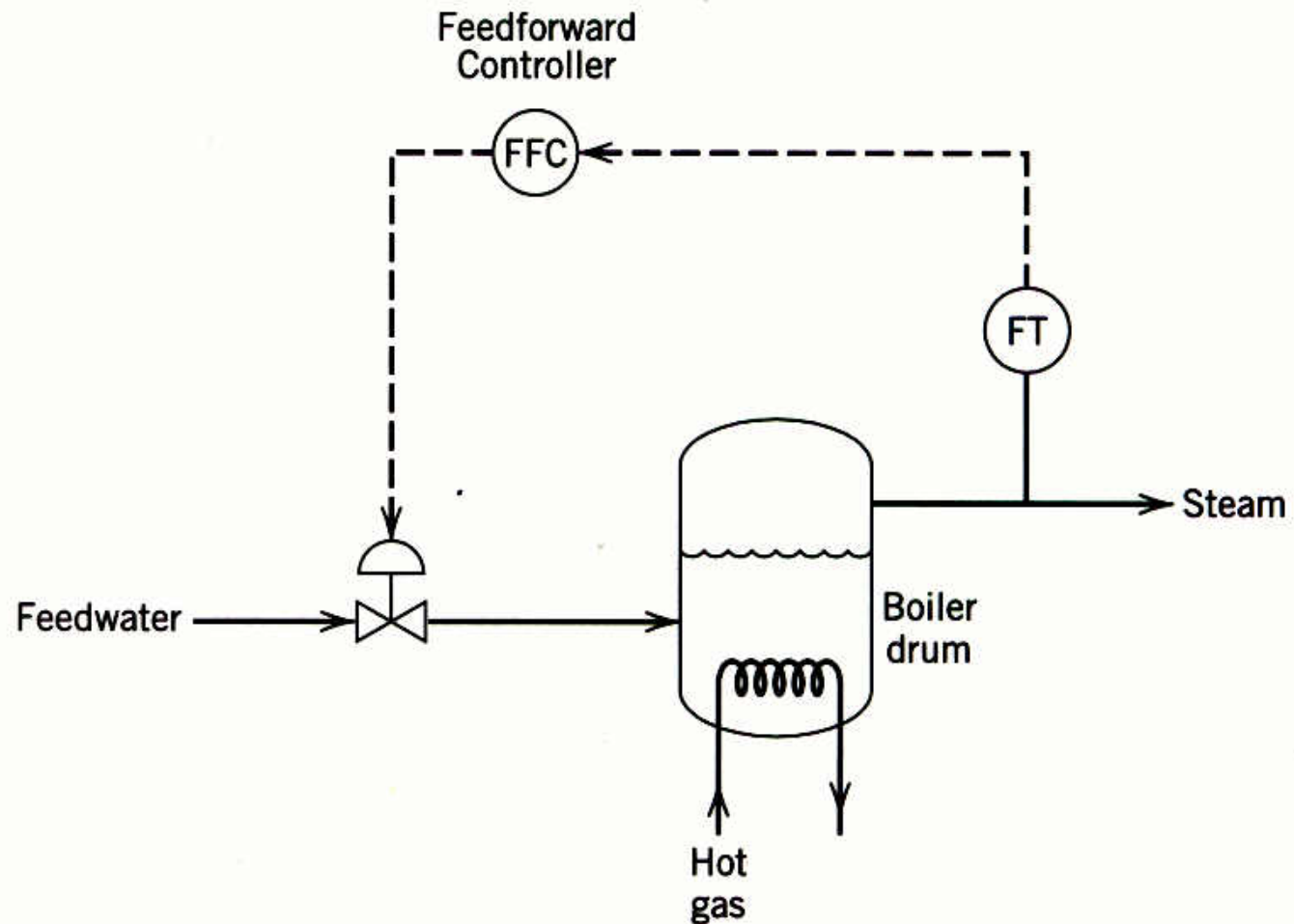

Figure 15.3 The feedforward control of the liquid level in a boiler drum.

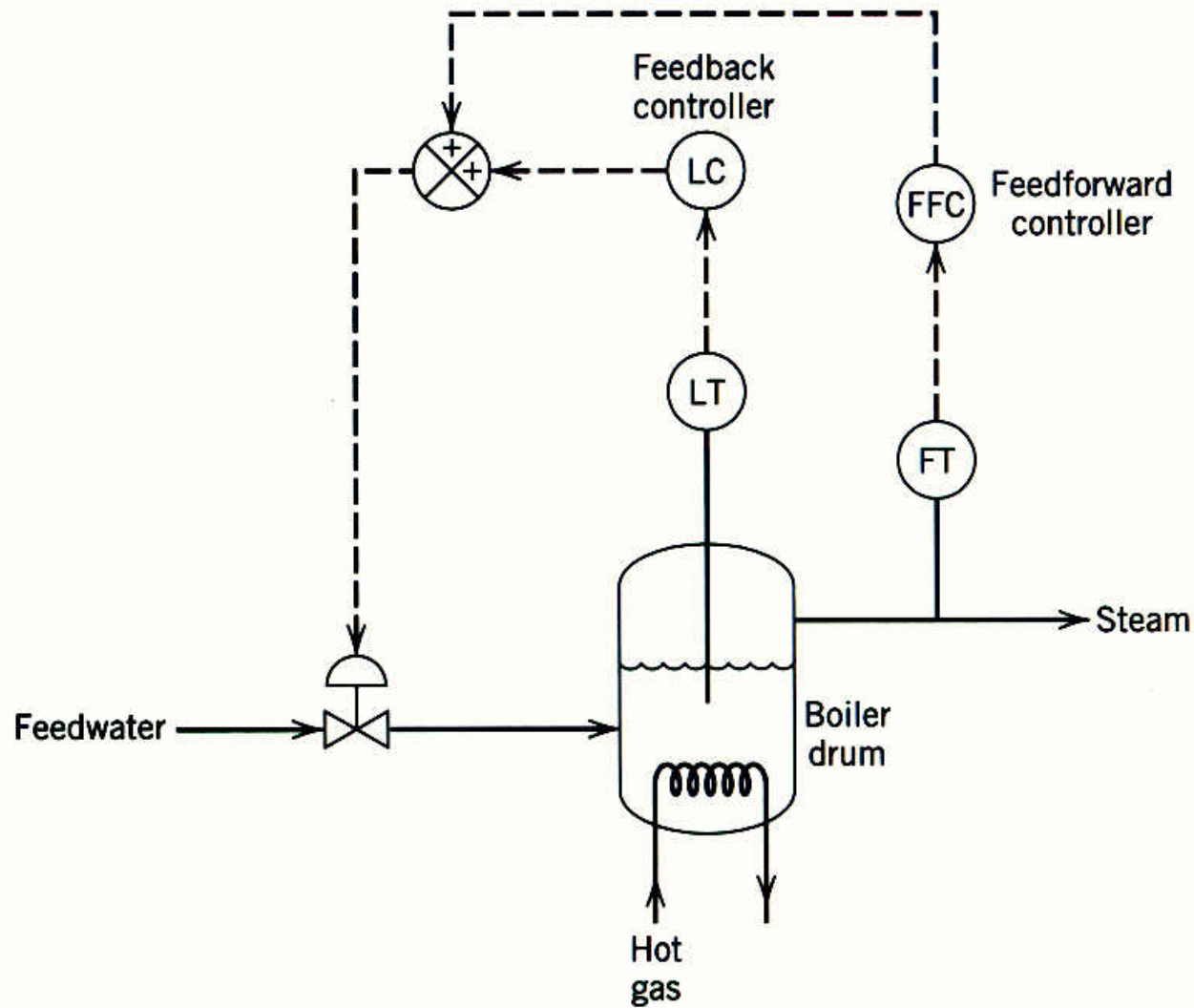

Figure 15.4 The feedforward-feedback control of the boiler drum level.

- In practical applications, feedforward control is normally used in combination with feedback control.
- Feedforward control is used to reduce the effects of measurable disturbances, while *feedback trim* compensates for inaccuracies in the process model, measurement error, and unmeasured disturbances.

Ratio Control

Ratio control is a special type of feedforward control that has had widespread application in the process industries. The objective is to maintain the ratio of two process variables as a specified value. The two variables are usually flow rates, a manipulated variable u , and a disturbance variable d . Thus, the ratio

$$R = \frac{u}{d} \quad (15-1)$$

is controlled rather than the individual variables. In Eq. 15-1, u and d are physical variables, not deviation variables.

Typical applications of ratio control include:

1. Setting the relative amounts of components in blending operations
2. Maintaining a stoichiometric ratio of reactants to a reactor
3. Keeping a specified reflux ratio for a distillation column
4. Holding the fuel-air ratio to a furnace at the optimum value.

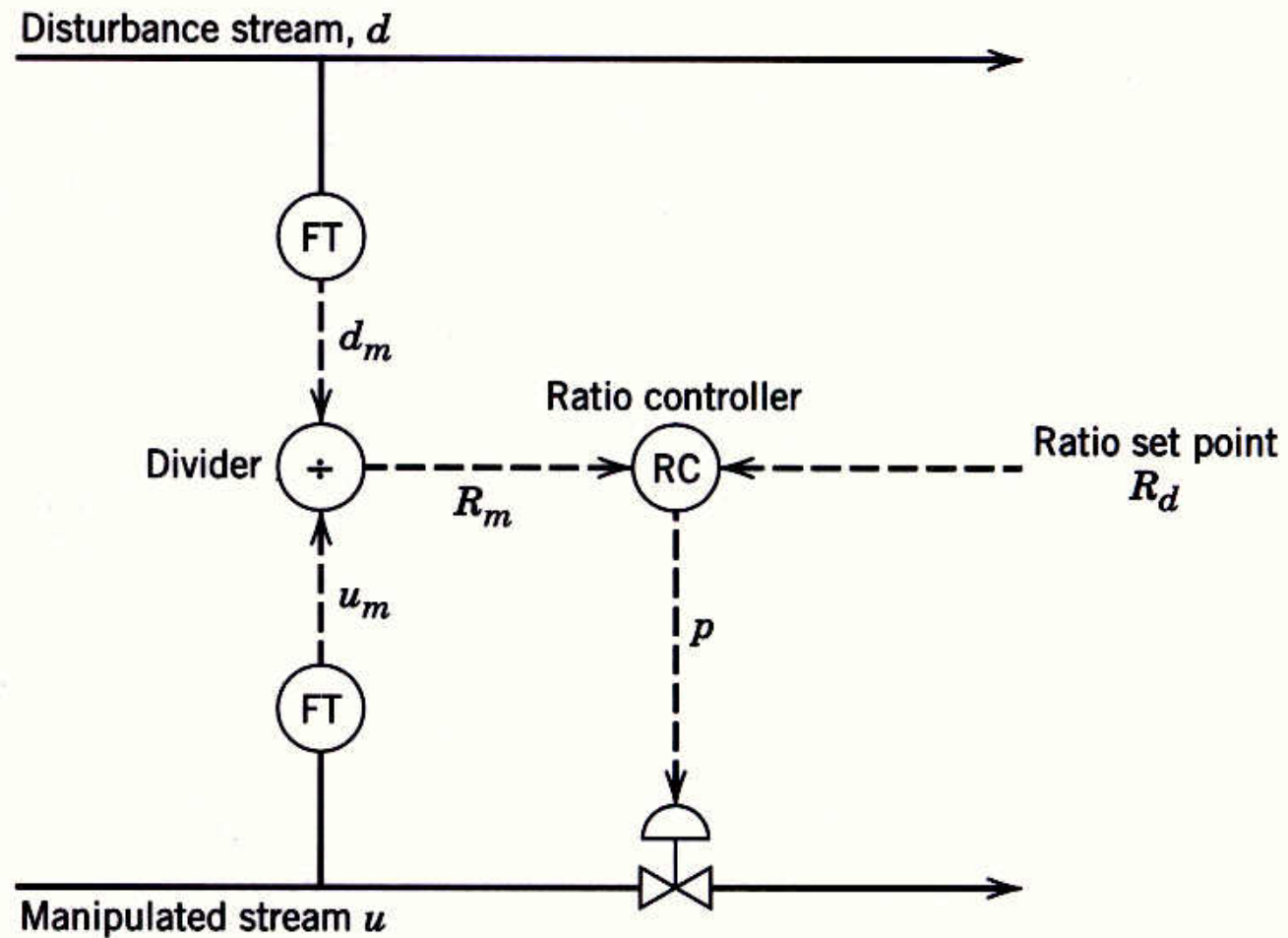

Figure 15.5 Ratio control, Method I.

- The main advantage of Method I is that the actual ratio R is calculated.
- A key disadvantage is that a divider element must be included in the loop, and this element makes the process gain vary in a nonlinear fashion. From Eq. 15-1, the process gain

$$K_p = \left(\frac{\partial R}{\partial u} \right)_d = \frac{1}{d} \quad (15-2)$$

is inversely related to the disturbance flow rate d' . Because of this significant disadvantage, the preferred scheme for implementing ratio control is Method II, which is shown in Fig. 15.6.

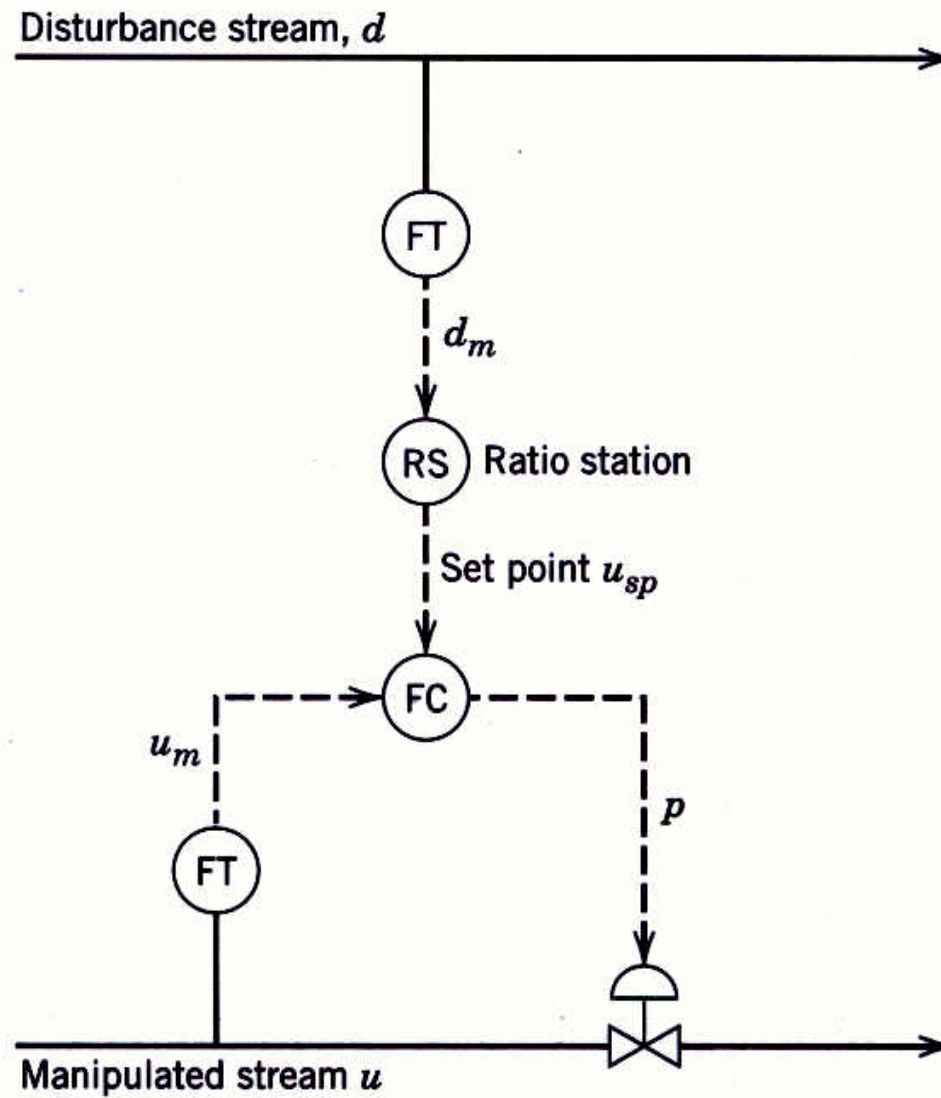

Figure 15.6 Ratio control, Method II

- Regardless of how ratio control is implemented, the process variables must be scaled appropriately.
- For example, in Method II the gain setting for the ratio station K_d must take into account the spans of the two flow transmitters.
- Thus, the correct gain for the ratio station is

$$K_R = R_d \frac{S_d}{S_u} \quad (15-3)$$

where R_d is the desired ratio, S_u and S_d are the spans of the flow transmitters for the manipulated and disturbance streams, respectively.

Example 15.1

A ratio control scheme is to be used to maintain a stoichiometric ratio of H_2 and N_2 as the feed to an ammonia synthesis reactor. Individual flow controllers will be used for both the H_2 and N_2 streams. Using the information given below, do the following:

- a) Draw a schematic diagram for the ratio control scheme.
- b) Specify the appropriate gain for the ratio station, K_R .

Available Information

- i. The electronic flow transmitters have built-in square root extractors. The spans of the flow transmitters are 30 L/min for H₂ and 15 L/min for N₂.
- ii. The control valves have pneumatic actuators.
- iii. Each required current-to-pressure (*I/P*) transducer has a gain of 0.75 psi/mA.
- iv. The ratio station is an electronic instrument with 4-20 mA input and output signals.

Solution

The stoichiometric equation for the ammonia synthesis reaction is

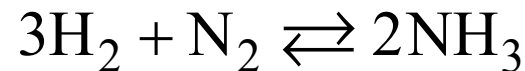

In order to introduce the feed mixture in stoichiometric proportions, the ratio of the molar flow rates (H_2/N_2) should be 3:1. For the sake of simplicity, we assume that the ratio of the molar flow rates is equal to the ratio of the volumetric flow rates. But in general, the volumetric flow rates also depend on the temperature and pressure of each stream (cf., the ideal gas law).

- a) The schematic diagram for the ammonia synthesis reaction is shown in Fig. 15.7. The H_2 flow rate is considered to be the disturbance variable, although this choice is arbitrary because both the H_2 and N_2 flow rates are controlled. Note that the ratio station is merely a device with an adjustable gain. The input signal to the ratio station is d_m , the measured H_2 flow rate. Its output signal u_{sp} serves as the set point for the N_2 flow control loop. It is calculated as $u_{sp} = K_R d_m$.

Chapter 15

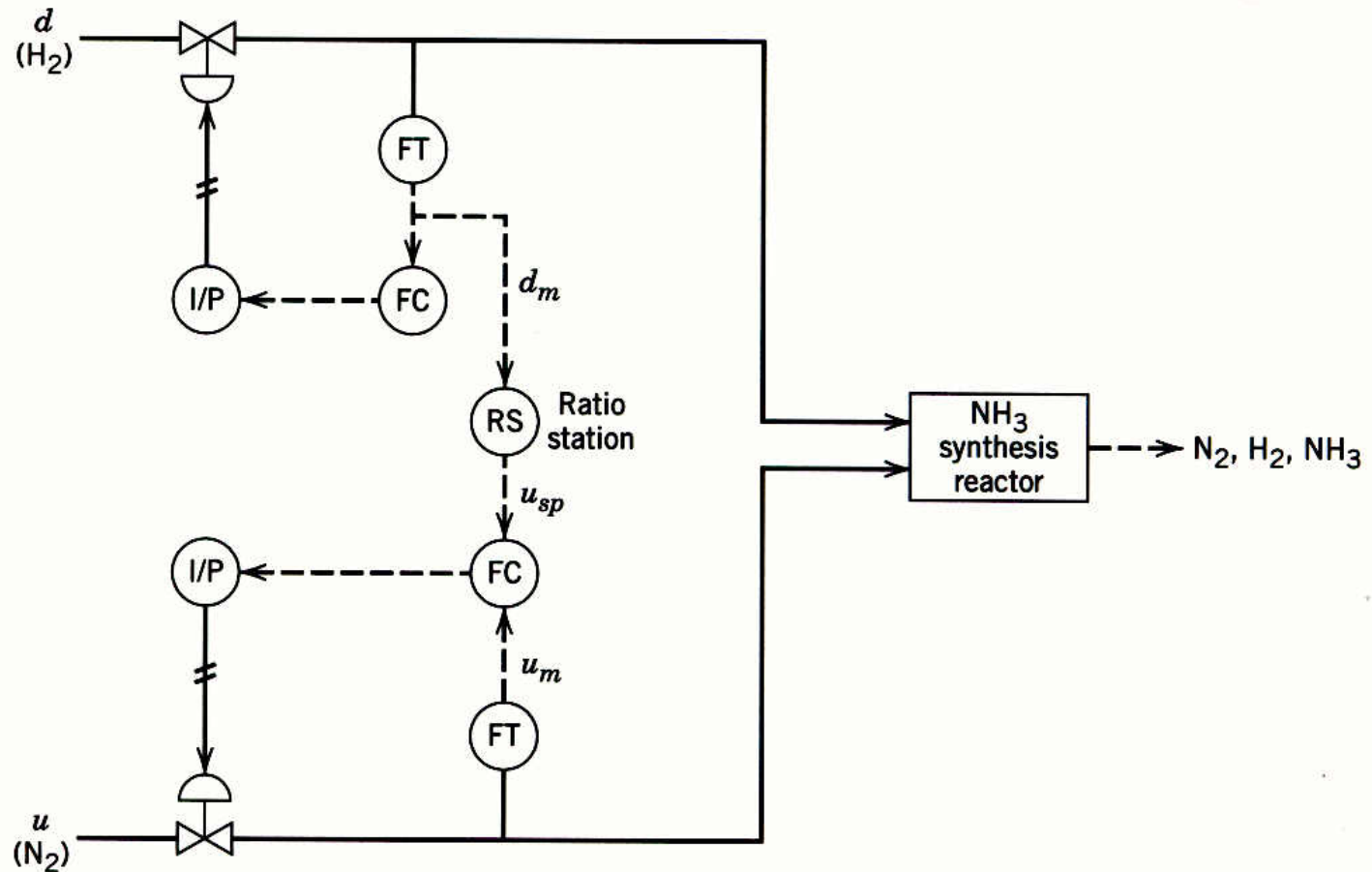

Figure 15.7 Ratio control scheme for an ammonia synthesis reactor of Example 15.1

b) From the stoichiometric equation, it follows that the desired ratio is $R_d = u/d = 1/3$. Substitution into Equation 15-3 gives:

$$K_R = \left(\frac{1}{3}\right) \left(\frac{30 \text{ L/min}}{15 \text{ L/min}}\right) = \frac{2}{3}$$

Feedforward Controller Design Based on Steady-State Models

- A useful interpretation of feedforward control is that it continually attempts to balance the material or energy that must be delivered to the process against the demands of the load.
- For example, the level control system in Fig. 15.3 adjusts the feedwater flow so that it balances the steam demand.
- Thus, it is natural to base the feedforward control calculations on material and energy balances.

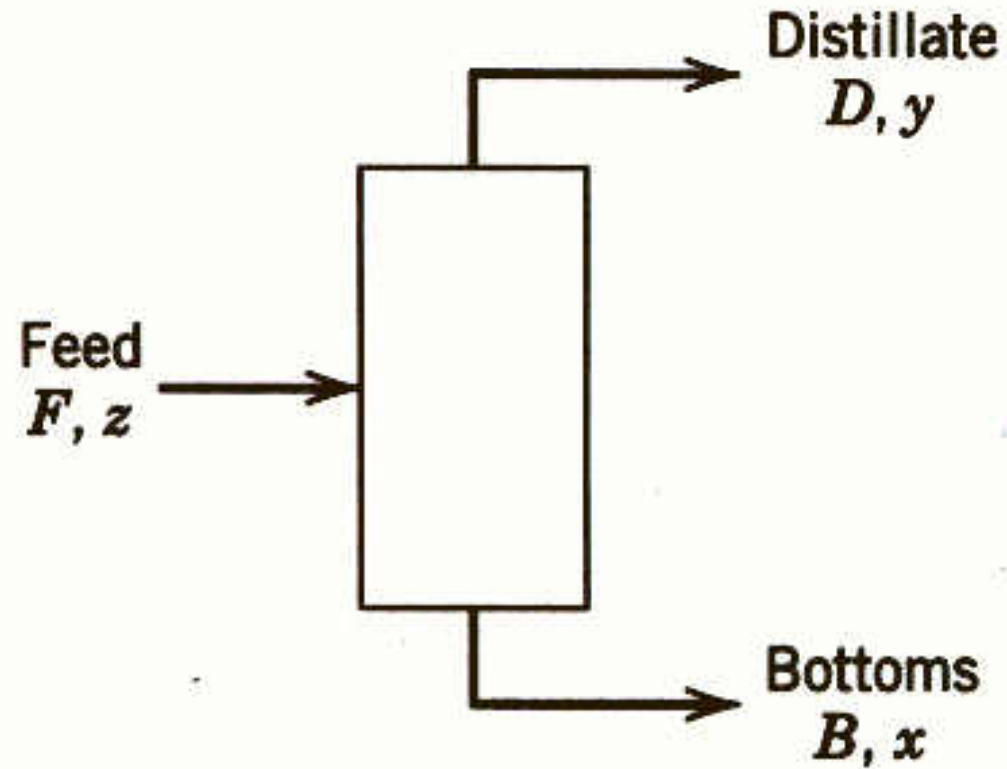

Figure 15.8 A simple schematic diagram of a distillation column.

- To illustrate the design procedure, consider the distillation column shown in Fig. 15.8 which is used to separate a binary mixture.
- In Fig. 15.8, the symbols B , D , and F denote molar flow rates, whereas x , y , and z are the mole fractions of the more volatile component.
- The objective is to control the distillation composition, y , despite measurable disturbances in feed flow rate F and feed composition z , by adjusting distillate flow rate, D .
- It is assumed that measurements of x and y are not available.

The steady-state mass balances for the distillation column can be written as

$$F = D + B \quad (15-4)$$

$$Fz = Dy + Bx \quad (15-5)$$

Solving (15-4) for D and substituting into (15-5) gives

$$D = \frac{F(z - x)}{y - x} \quad (15-6)$$

Because x and y are not measured, we replace these variables by their set points to yield the feedforward control law:

$$D = \frac{F(z - x_{sp})}{y_{sp} - x_{sp}} \quad (15-7)$$

Blending System

- Consider the blending system and feedforward controller shown in Fig. 15.9.
- We wish to design a feedforward control scheme to maintain exit composition x at a constant set point x_{sp} , despite disturbances in inlet composition, x_1 .
- Suppose that inlet flow rate w_1 and the composition of the other inlet stream, x_2 , are constant.
- It is assumed that x_1 is measured but x is not.

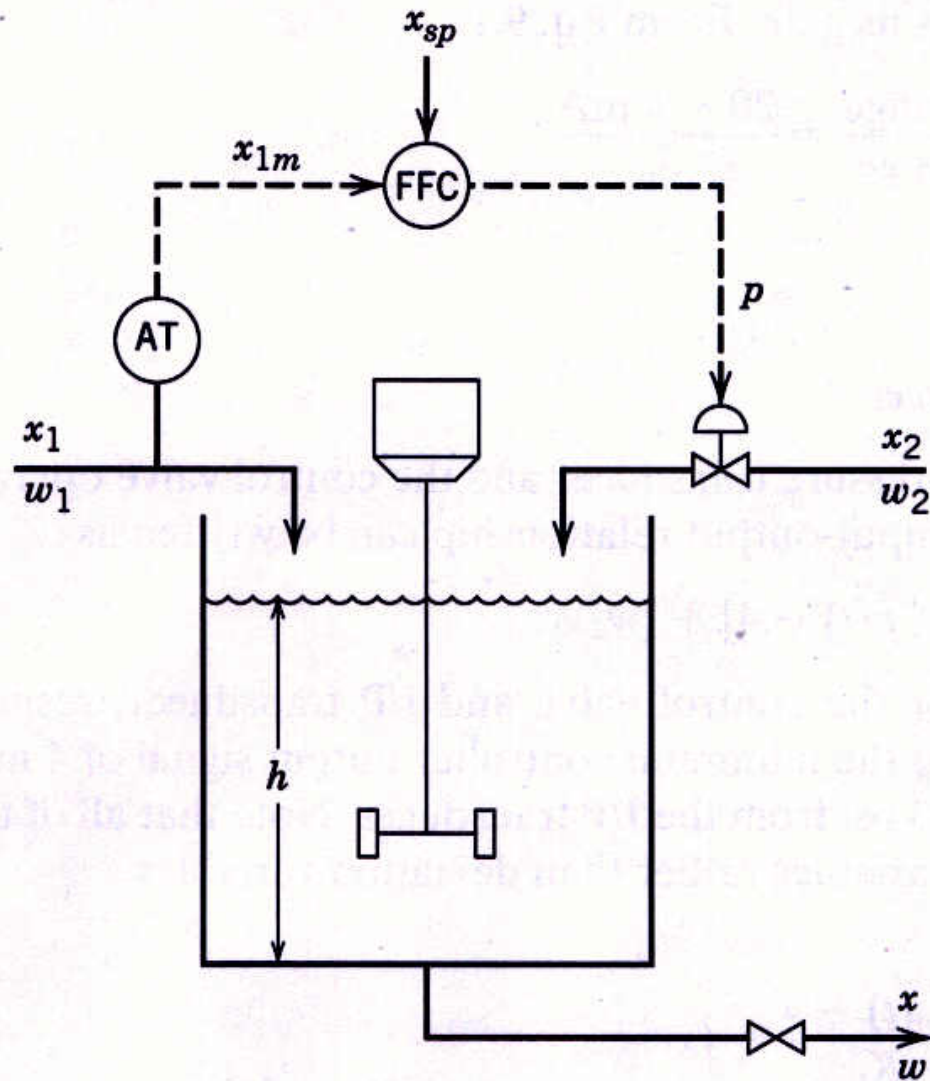

Figure 15.9 Feedforward control of exit composition in the blending system.

The starting point for the feedforward controller design is the steady-state mass and component balances,

$$\bar{w} = \bar{w}_1 + \bar{w}_2 \quad (15-8)$$

$$\bar{w}\bar{x} = \bar{w}_1\bar{x}_1 + \bar{w}_2\bar{x}_2 \quad (15-9)$$

where the bar over the variable denotes a steady-state value. Substituting Eq. 15-8 into 15-9 and solving for \bar{w}_2 gives:

$$\bar{w}_2 = \frac{\bar{w}_1(\bar{x} - \bar{x}_1)}{\bar{x}_2 - \bar{x}} \quad (15-10)$$

In order to derive a feedforward control law, we replace \bar{x} by x_{sp} , and \bar{w}_2 and \bar{x}_1 , by $w_2(t)$ and $x_1(t)$, respectively:

$$w_2(t) = \frac{\bar{w}_1 [x_{sp} - x_1(t)]}{\bar{x}_2 - x_{sp}} \quad (15-11)$$

Note that this feedforward control law is based on the physical variables rather than on the deviation variables.

- The feedforward control law in Eq. 15-11 is not in the final form required for actual implementation because it ignores two important instrumentation considerations:
- First, the actual value of x_1 is not available but its measured value, x_{1m} , is.
- Second, the controller output signal is p rather than inlet flow rate, w_2 .
- Thus, the feedforward control law should be expressed in terms of x_{1m} and p , rather than x_1 and w_2 .
- Consequently, a more realistic feedforward control law should incorporate the appropriate steady-state instrument relations for the w_2 flow transmitter and the control valve. (See text.)

Feedforward Controller Design Based on Dynamic Models

In this section, we consider the design of feedforward control systems based on dynamic, rather than steady-state, process models.

- As a starting point for our discussion, consider the block diagram shown in Fig. 15.11.
- This diagram is similar to Fig. 11.8 for feedback control but an additional signal path through G_t and G_f has been added.

Chapter 15

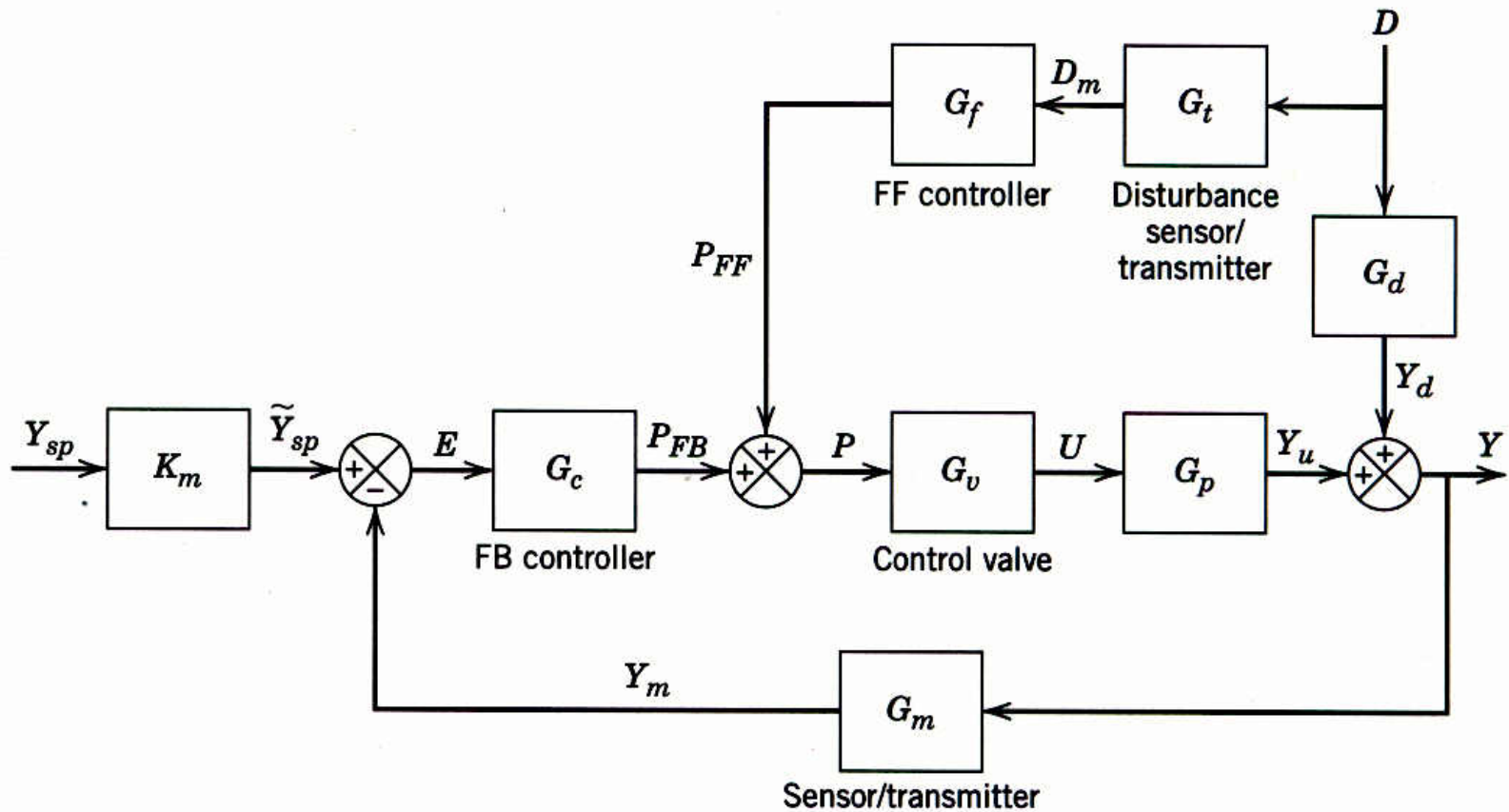

Figure 15.11 A block diagram of a feedforward-feedback control system.

The closed-loop transfer function for disturbance changes is:

$$\frac{Y(s)}{D(s)} = \frac{G_d + G_t G_f G_v G_p}{1 + G_c G_v G_p G_m} \quad (15-20)$$

Ideally, we would like the control system to produce *perfect control* where the controlled variable remains exactly at the set point despite arbitrary changes in the disturbance variable, D . Thus, if the set point is constant ($Y_{sp}(s) = 0$), we want $Y(s) = 0$, even though $D(s)$

$$G_f = -\frac{G_d}{G_t G_v G_p} \quad (15-21)$$

- Figure 15.11 and Eq. 15-21 provide a useful interpretation of the ideal feedforward controller. Figure 15.11 indicates that a disturbance has two effects.
- It upsets the process via the disturbance transfer function, G_d ; however, a corrective action is generated via the path through $G_t G_f G_v G_p$.

- Ideally, the corrective action compensates exactly for the upset so that signals Y_d and Y_u cancel each other and $Y(s) = 0$.

Example 15.2

Suppose that

$$G_d = \frac{K_d}{\tau_d s + 1}, \quad G_p = \frac{K_p}{\tau_p s + 1} \quad (15-22)$$

Then from (15-22), the ideal feedforward controller is

$$G_f = - \left(\frac{K_d}{K_t K_v K_p} \right) \left(\frac{\tau_p s + 1}{\tau_d s + 1} \right) \quad (15-23)$$

This controller is a lead-lag unit with a gain given by $K_f = -K_d/K_t K_v K_p$. The dynamic response characteristics of lead-lag units were considered in Example 6.1 of Chapter 6.

Example 15.3

Now consider

$$G_d = \frac{K_d}{\tau_d s + 1}, \quad G_p = \frac{K_p e^{-\theta s}}{\tau_p s + 1} \quad (15-24)$$

From (15-21),

$$G_f = \left(\frac{K_d}{K_t K_v K_p} \right) \left(\frac{\tau_p s + 1}{\tau_d s + 1} \right) e^{+\theta s} \quad (15-25)$$

Because the term $e^{+\theta s}$ is a *negative time delay*, implying a predictive element, the ideal feedforward controller in (15-25) is *physically unrealizable*. However, we can approximate it by omitting the $e^{+\theta s}$ term and increasing the value of the lead time constant from τ_p to $\tau_p + \theta$.

Example 15.4

Finally, if

$$G_d = \frac{K_d}{\tau_d s + 1}, \quad G_p = \frac{K_p}{(\tau_{p1} s + 1)(\tau_{p2} s + 1)} \quad (15-26)$$

then the ideal feedforward controller,

$$G_f = - \left(\frac{K_d}{K_t K_v K_p} \right) \frac{(\tau_{p1} s + 1)(\tau_{p2} s + 1)}{(\tau_d s + 1)} \quad (15-27)$$

is *physically unrealizable* because the numerator is a higher order polynomial in s than the denominator. Again, we could approximate this controller by a physically realizable one such as a lead-lag unit, where the lead time constant is the sum of the two time constants, $\tau_{p1} + \tau_{p2}$.

Stability Considerations

- To analyze the stability of the closed-loop system in Fig. 15.11, we consider the closed-loop transfer function in Eq. 15-20.
- Setting the denominator equal to zero gives the characteristic equation,

$$1 + G_c G_v G_p G_m = 0 \quad (15-28)$$

- In Chapter 11 it was shown that the roots of the characteristic equation completely determine the stability of the closed-loop system.
- Because G_f does not appear in the characteristic equation, the feedforward controller has no effect on the stability of the feedback control system.
- This is a desirable situation that allows the feedback and feedforward controllers to be tuned individually.

Lead-Lag Units

- The three examples in the previous section have demonstrated that lead-lag units can provide reasonable approximations to ideal feedforward controllers.
- Thus, if the feedforward controller consists of a lead-lag unit with gain K_f , we can write

$$G_f(s) = \frac{U(s)}{D(s)} = \frac{K_f(\tau_1 s + 1)}{\tau_2 s + 1} \quad (15-29)$$

Example 15.5

Consider the blending system of Section 15.3 and Fig. 15.9. A feedforward-feedback control system is to be designed to reduce the effect of disturbances in feed composition, x_1 , on the controlled variable, produce composition, x . Inlet flow rate, w_2 , can be manipulated. (See text.)

Configurations for Feedforward-Feedback Control

In a typical control configuration, the outputs of the feedforward and feedback controllers are added together, and the sum is sent as the signal to the final control element. Another useful configuration for feedforward-feedback control is to have the feedback controller output serve as the set point for the feedforward controller.

Chapter 15

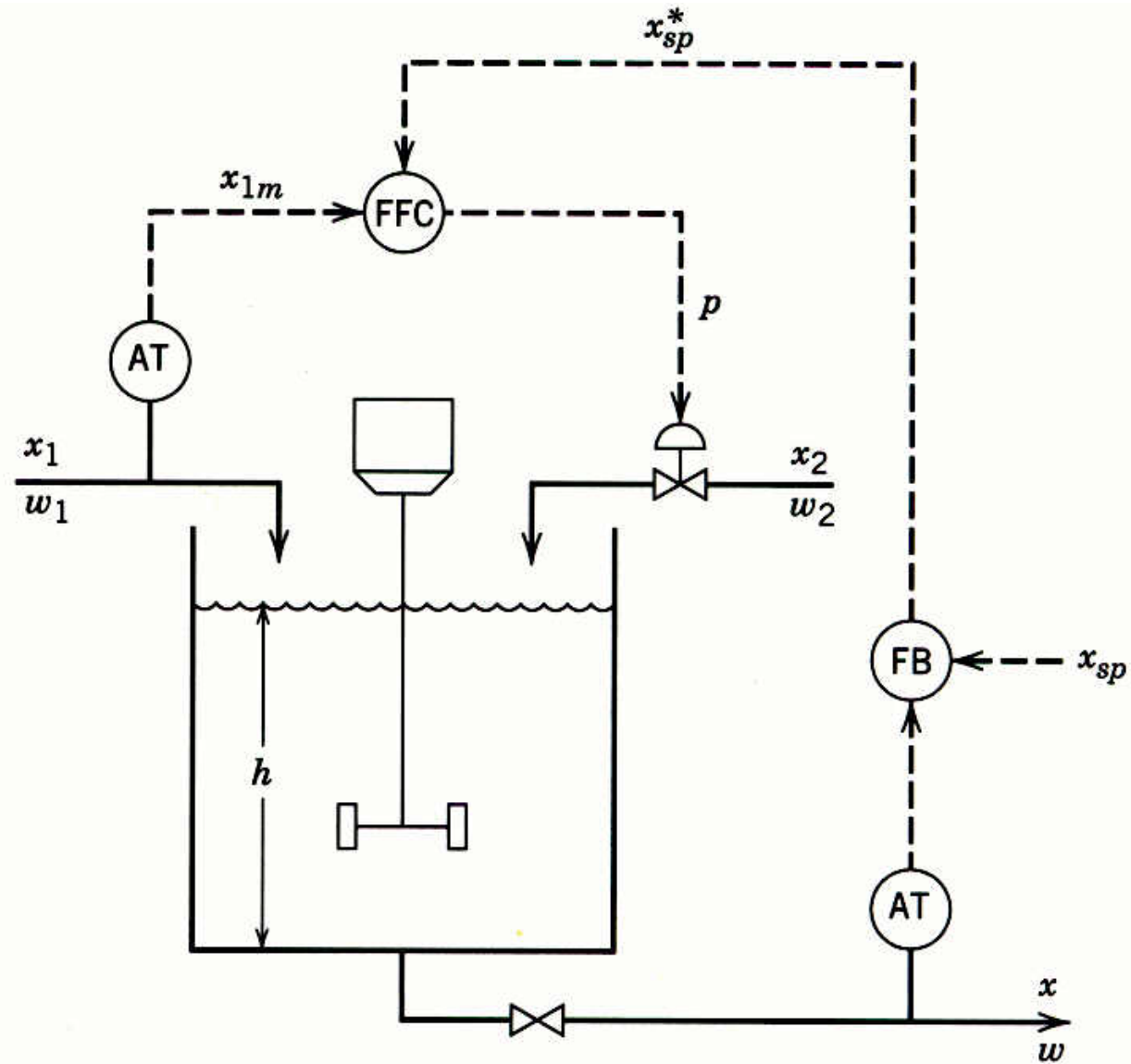
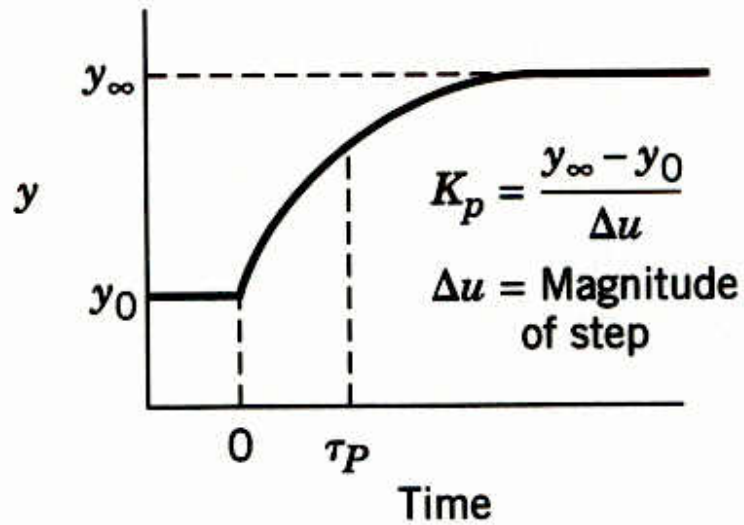
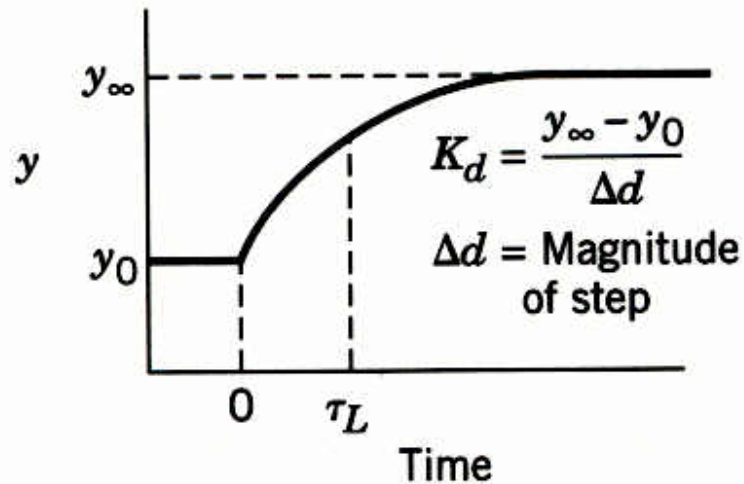

Figure 15.14 Feedforward-feedback control of exit composition in the blending system.



(a) Step change in u



(b) Step change in d ($\Delta d < 0$)

Figure 15.15 The open-loop responses to step changes in u and d .

Tuning Feedforward Controllers

Feedforward controllers, like feedback controllers, usually require tuning after installation in a plant.

Step 1. *Adjust K_f*

- The effort required to tune a controller is greatly reduced if good initial estimates of the controller parameters are available.
- An initial estimate of K_f can be obtained from a steady-state model of the process or steady-state data.
- For example, suppose that the open-loop responses to step changes in d and u are available, as shown in Fig. 15.15.
- After K_p and K_d have been determined, the feedforward controller gain can be calculated from the steady-state version of Eq. 15-22:

$$K_f = -\frac{K_d}{K_t K_v K_p} \quad (15-40)$$

- To tune the controller gain, K_f is set equal to an initial value, and a small step change (3 to 5%) in the disturbance variable d is introduced, if this is feasible.
- If an offset results, then K_f is adjusted until the offset is eliminated.
- While K_f is being tuned, τ_1 and τ_2 should be set equal to their minimum values, ideally zero.

Step 2. *Determine initial values for τ_1 and τ_2 .*

- Theoretical values for τ_1 and τ_2 can be calculated if a dynamic model of the process is available, as shown in Example 15.2.
- Alternatively, initial estimates can be determined from open-loop response data.
- For example, if the step responses have the shapes shown in Figure 15.16, a reasonable process model is

$$G_p(s) = \frac{K_p}{\tau_p s + 1}, \quad G_d(s) = \frac{K_d}{\tau_d s + 1} \quad (15-41)$$

where τ_p and τ_d can be calculated as shown in Fig. 15.16.

- A comparison of Eqs. 15-24 and 5-30 leads to the following expression for τ_1 and τ_2 :

$$\tau_1 = \tau_p \quad (15-42)$$

$$\tau_2 = \tau_d \quad (15-43)$$

- These values can then be used as initial estimates for the fine tuning of τ_1 and τ_2 in Step 3.
- If neither a process model nor experimental data are available, the relations $\tau_1 / \tau_2 = 2$ or $\tau_1 / \tau_2 = 0.5$ may be used, depending on whether the controlled variable responds faster to the load variable or to the manipulated variable.

- In view of Eq. 15-58, τ_1 should be set equal to the estimated dominant process time constant.

Step 3. *Fine tune τ_1 and τ_2 .*

- The final step is to use a trial-and-error procedure to fine tune τ_1 and τ_2 by making small step changes in d .
- The desired step response consists of small deviations in the controlled variable with equal areas above and below the set point [1], as shown in Fig. 15.17.
- For simple process models, it can be proved theoretically that equal areas above and below the set point imply that the difference, $\tau_1 - \tau_2$, is correct (Exercise 15.8).
- In subsequent tuning to reduce the size of the areas, τ_1 and τ_2 should be adjusted so that $\tau_1 - \tau_2$ remains constant.

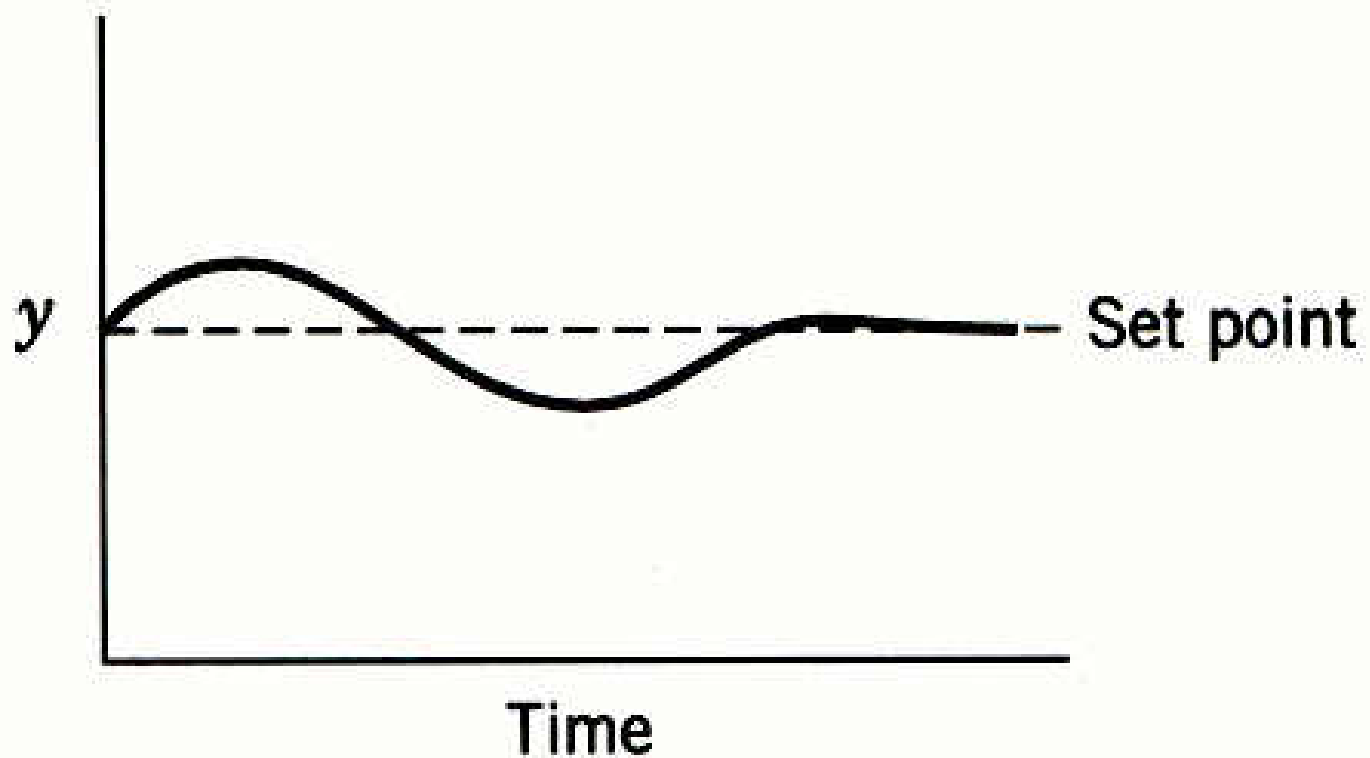

Figure 15.16 The desired response for a well-tuned feedforward controller. (Note approximately equal areas above and below the set point.)

As a hypothetical illustration of this trial-and-error tuning procedure, consider the set of responses shown in Fig. 15.17 for positive step changes in disturbance variable d . It is assumed that $K_p > 0$, $K_d < 0$, and controller gain K_f has already been adjusted so that offset is eliminated.

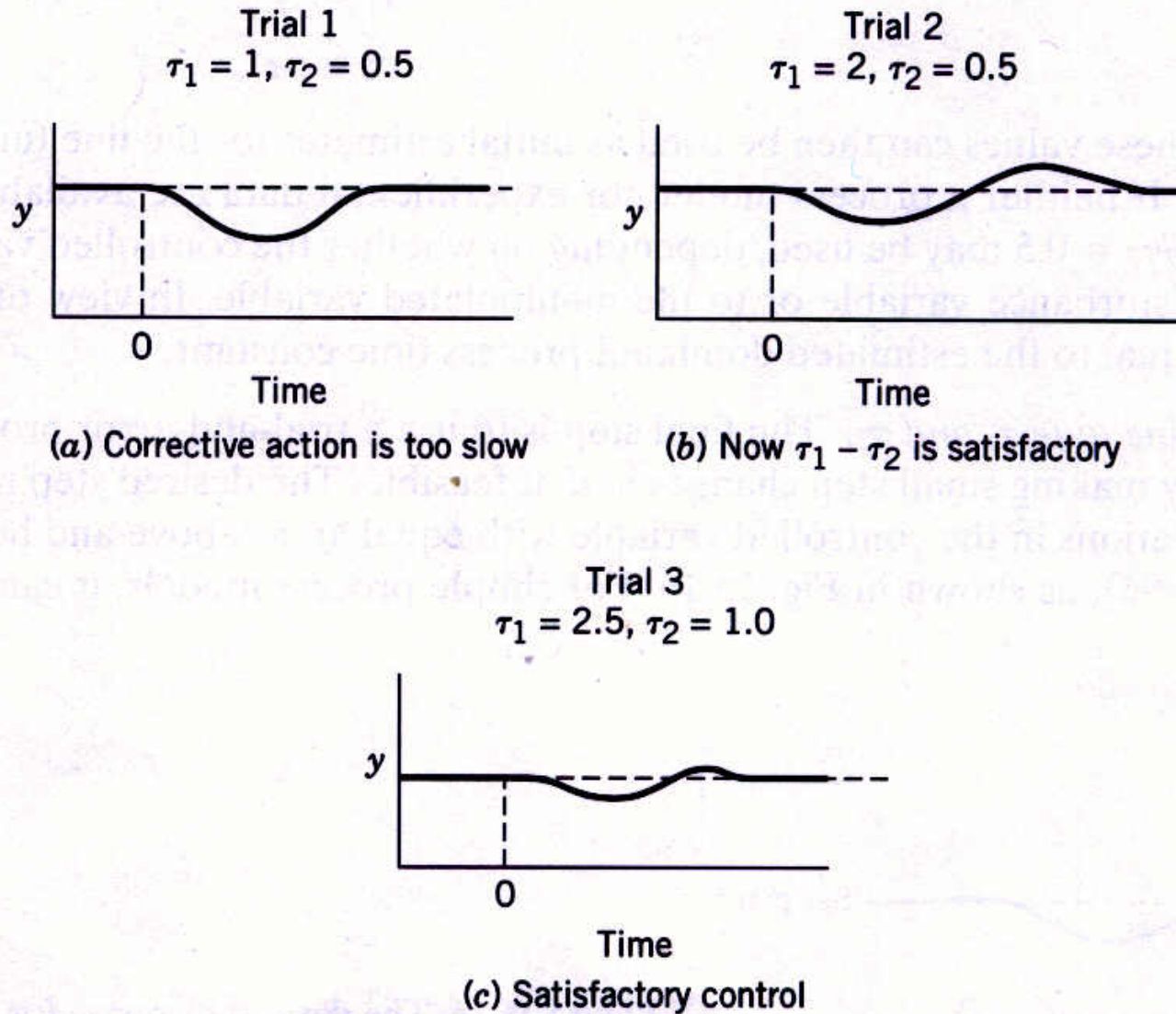

Figure 15.17 An example of feedforward controller tuning.